

J2

Model I40 Modulating electric actuator



Doc: J2-I40DPS2005/02KW

Aug 2010

J2 – I40 IP65 Modulating Electric Actuator

The maintenance free **J2** electric actuator is very user friendly. It offers more standard features than any rivals in its class, and was first to the market with both multi-voltage capability with automatic voltage sensing, and an electronic torque limiter with auto-gearbox relaxing which frees the manual override when a valve is jammed. The manual override facility, with a safety power cut-out switch when operated, allows safe hand operation .

Time saving external DIN plugs allow installations to be pre-wired and eliminates the need to remove the cover to connect the actuator, which helps to reduce installation costs.

With a soft start system eliminating high motor start loads and a thermostatic anti-condensation heater that does not require a separate connection, the **J2** offers low power consumption.

The IP65 weatherproof plastic housing with stainless steel cover screws offers excellent corrosion resistance.

Local visual position indication and remote volt free end of travel confirmation are provided as standard.

The **J2** is quick and easy to install:

- ISO:5211 multi-flange F07/F10 mounting with a 22mm female double square (star) drive.
- Factory set open and closed positions at 0 and 90° (or as specified on your order).
- External electrical connections and external wiring diagram- no need to remove the cover to connect.



Note: Always read the supplied installation & operating instructions (IOM's) before use.

J2 -Model I40 DPS ~ Digital Positioning System

Digital Positioning System 2005 (DPS.2005)

This version uses a factory fitted internal digital positioner to control the movement of the actuator relative to a control signal, either 4-20mA or 0-10VDC, and provides an output signal as standard.

The DPS.2005 is a self calibrating and auto-adjusting unit. On first power-up, the positioner sets the span based on the motor open and closed positions. Should the actuator be over-rotated whilst in manual operation, when it is placed back in automatic function the positioner will automatically self adjust back to the original settings based on the motor open and closed positions.

The DPS.2005 arrives at the desired position and stops, eliminating hunting.

Main Features: Model J2 Modulating electric actuator

*Multi-voltage electric actuator
with auto-voltage sensing:*

J2-L140 12-48V AC/DC

J2-H140 80-240V AC/DC

Torque output::

170Nm Break

140Nm Reset

*Electronic torque limiter ~
protects against valve jams*

Anti-condensation heater

Manual override

*All connections via external
DIN plugs ~ no need to
remove the cover to connect*

*Volt free end of travel
confirmation switches*

IP65 weatherproof housing

CE marked

*Traceable sequential
serial numbering system*

*Modulating function by our
DPS self calibrating and auto-
adjusting digital positioning
system with feedback.*

*4-20mA control with
4-20mA output or
0-10VDC control with
0-10VDC output.*

Specifications: J2 – I40 DPS Electric actuator (Modulating)

Models	J2 -HI40-D4 80-240V AC (1ph) or DC 4-20mA J2 -LI40 -D4 12-48V AC (1ph) or DC 4-20mA J2 -HI40-D0 80-240V AC (1ph) or DC 0-10VDC J2 -LI40 -D0 12-48V AC (1ph) or DC 0-10VDC
Housing	IP65 Anti-corrosive Polyamide
Duty Rating	100%
Mounting	ISO5211 & DIN3337
Electrical Connection	External via DIN plugs
Torque Output	170Nm Break, 140Nm Run & re-seat
Temp Range	-20°C to +70°C
Working Time (0-90°)	33 Secs ± 10%, no load
Current 220VAC/ 110VAC	230 mA 50.6W / 700 mA 77.0W
Current 24VAC/ 24VDC	3600 mA 86.4W / 3000 mA 72.0W
Weight	6 kg

Dimensions:

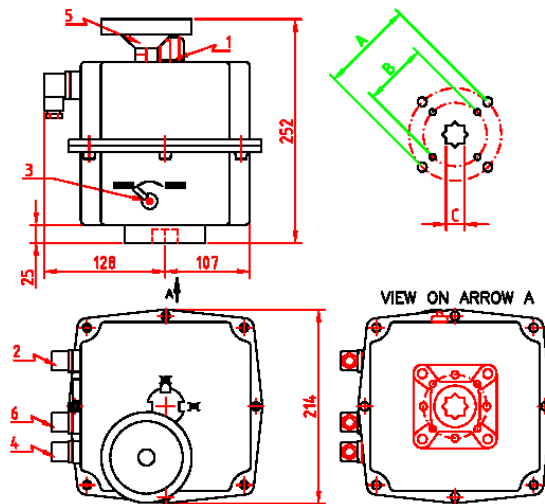

On/off, stays put on power failure:

- A/B: Multi-flange: F07/10 ISO5211
- C: 22mm double square (star)

- 1 Local visual position indicator
- 2 Power supply DIN plug
- 3 Manual override selector lever
- 4 Volt free limit switch DIN plug
- 5 Manual override hand wheel
- 6 Control signal DIN plug

Wiring:

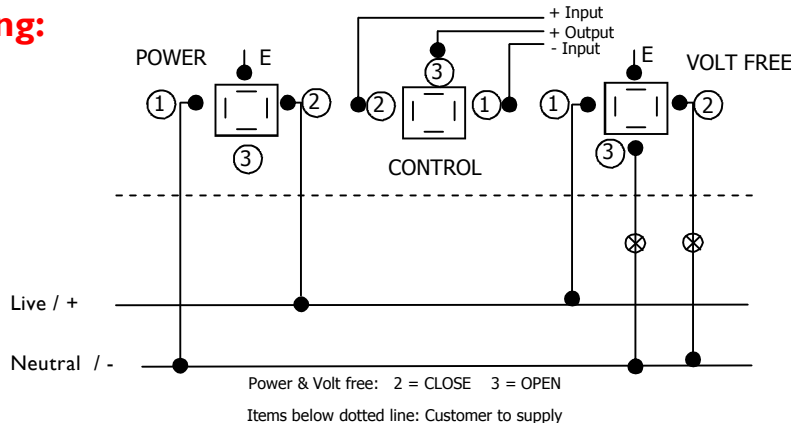

Wiring Diagram (AC or DC): 2 wire

- Notes:
- DIN plugs supplied with actuator.
- Control signal plug rotated by 180°.