

J2-L20-DPS Modulating IP65 Weatherproof Electric Actuator

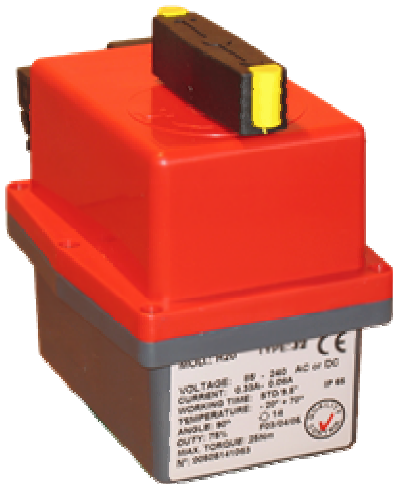

Features:

- > **Auto-voltage sensing**
- Accepts 24~48V AC & DC
- > **Electronic torque limiter**
- Protects against valve jams
- > **Anti-condensation heater**
- Protects against condensation
- > **Manual override**
- > **Digital positioner, 0-10V DC or 4-20mA input & output**

TYPE J2-L20-DPS

General:

The J2 Smart Redbox electric actuator offers multi-voltage capability, electronic torque limiter, anti-condensation heater, local and remote position confirmation and a manual override with safety cut-out switch when activated.

Internally factory fitted Digital Positioning System (DPS) provides accurate modulating function with either 0-10VDC or 4-20mA control signal. Output signal provided.

Specifications:

Housing	Polyamide (Nylon 6)
Duty rating	100%
Drive connection	ISO5211 & DIN 3337
Electrical connection	External via DIN plugs
Torque output	25Nm break, 20Nm running
Temp range	-20°C to +70°C
Working time	8 secs ± 10%, no load
Supply voltages	24~48V AC or DC
Current 24V DC	900 mA 21.6 W
Current 24V AC	1900 mA 45.6 W
Weight	1.7 kg
DPS Accuracy	0.3%
DPS Linearity	3%
DPS Hysteresis	2%

Installation:

The J2 Smart Redbox is remarkably simple to install as all electrical connections are made without removing the actuator's cover - the supplied DIN plugs are wired in accordance with the opposite wiring diagram, re-connected to the actuator and the J2 is ready for use. The J2 can be mounted in any orientation but vertical orientation is preferred.

Read supplied installation & operating instructions before use. Care must be taken not to over rotate beyond OPEN and CLOSED logos when in 'MAN' otherwise DPS can lose settings

Dimensions:

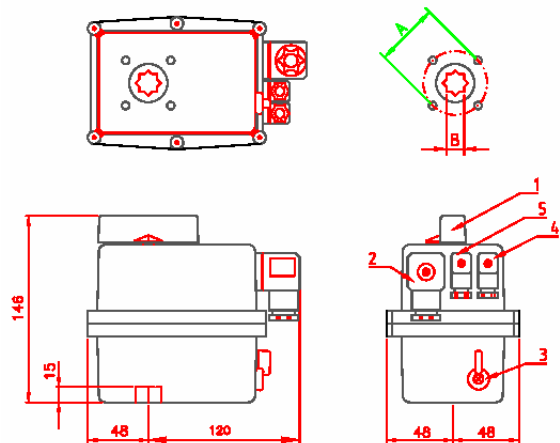

Modulating, stays put on power failure: Type J2-L20-DPS

- | | | |
|---|--|---------------|
| 1 | Manual override & local position indicator | A: F03 or F05 |
| 2 | Power supply DIN plug | B: 11 or 14mm |
| 3 | Manual override selector lever | A: ISO5211 |
| 4 | Volt free limit switch DIN plug | B: DIN3337 |
| 5 | Control signal input/ output | |

Wiring Diagram (AC or DC):

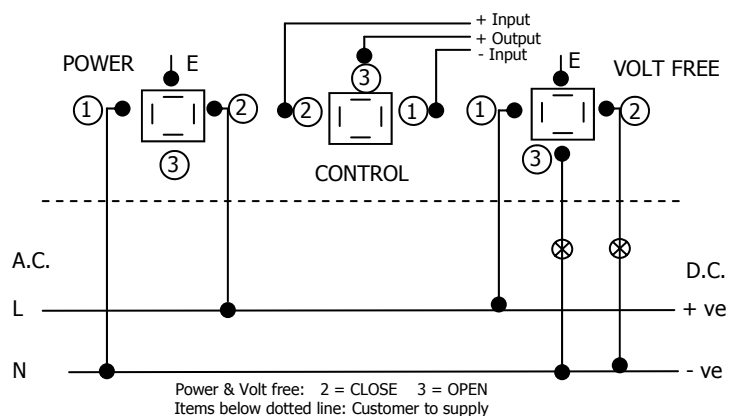

J2 SMART REDBOX – INSTALLATION, OPERATION & MAINTENANCE INSTRUCTIONS

Read these instructions **BEFORE** attempting to use the actuator as damage caused by non-compliance will invalidate any warranty. If in any doubt, ask your supplier **BEFORE** using it.

STANDARD FEATURES:

AVS (Auto Voltage Sensing)

The J2 actuator has multi-voltage capability – it can accept a range of AC or DC power supply voltages. The J2-L series can accept from 16V to 48V AC or DC, the J2-H series from 80 to 240V AC or DC.

PES (Protected Electrical Supply)

The J2 is protected against erroneous electrical connection – if the open live and closed live terminals are inadvertently connected, whilst the actuator will not operate, no internal damage should be caused. There are no fuses. Damage will only be caused by applying a voltage in excess of 48V AC or DC to the 'L' series actuators.

ETL (Electronic Torque Limiter)

An electronic torque limiter is fitted to all J2 actuators. The ETL constantly monitors the motor load and immediately cuts the motor power supply if the 'set point' is exceeded. An internal LED, in models 20 & 55, visible through the actuator's housing, provides constant status indication: constantly lit LED = actuator working normally, flashing LED = fault warning, the torque in the valve has exceeded the 'set point'. This advises operators that a problem has arisen with the valve (eg: blockage). A flashing LED indicates a fault with the valve, not the actuator. The ETL automatically 'backs off' when activated to relax the gears, allowing the manual override to be used to assist in clearing the blockage. Once the cause of the excess torque has been cleared, the J2 will automatically reset, the LED will change to being constantly lit, and the actuator will start operating again. See instructions overleaf.

ATC (Auto Temperature Control)

An inbuilt thermostat and heater maintains the internal temperature at around 30°C to prevent the possibility of condensation forming within the housing. This system does not require a separate power supply, it is fed from the main power supply. The power supply must remain on at all times for the heater to operate.

MO (Manual Override)

All J2 actuators have a manual override facility to allow manual operation in the event of power failure. Selection of manual ('MAN') operation operates an internal switch which cuts the motor power – the actuator will not operate electrically whilst in manual.

VFC (Volt Free Contacts)

All J2 actuators have an additional pair of volt free mechanical micro-switch contacts which are typically used for remote position confirmation. These switches are NOT to be used for actuator motor control.

Plus: IP65 weatherproof housing, but not suitable for submersion, flooding, hose down or pressure washing. 75% duty cycle. Corrosion resistant housing with stainless cover fixings. All external electrical connection via DIN plugs, eliminating the need to remove the cover to connect. ISO5211 and DIN3337 mounting. Local visual position indicator, CE marked, ISO9002 manufactured. Serial numbered and traceable.

QUICK AND EASY TO INSTALL

These user friendly actuators are designed to be fully connected WITHOUT REMOVING THE ACTUATOR COVER via externally supplied DIN plugs, simply wire the plugs and they are ready for use ! A wiring diagram label showing how to wire the plugs is affixed to the side of the actuator.

Standard wiring (3 wire) for either AC or DC power supply is identical with a common, and a live switch between open and close. However, for DC power supplies, the actuators will also operate on a 2 wire system with a user supplied voltage polarity switch, used to reverse the motor, if this wiring configuration is preferred.

PEACE OF MIND

The J2 actuators are fully guaranteed against manufacturing and/ or material defects, for 12 calendar months from the date of despatch from our works.

Thank you for purchasing the J2 Smart RedBox. We trust that you will find them very user friendly and that if installed and operated in accordance with the following instructions, they will give you reliable and trouble free performance.

E&OE 12-02 Rev 3

INSTALLATION, OPERATION & MAINTENANCE INSTRUCTIONS

STANDARD J2 ELECTRIC ACTUATORS (POWER OPEN, POWER CLOSE)

INSTALLATION INSTRUCTIONS

J2 actuators operate using live electricity and we strongly recommend that only qualified electricians/ electrical engineers be employed to make electrical connections. They are quick and easy to connect without removing the cover, do not remove the cover without our authorisation or the warranty may be invalidated:

- I.1 Check that the voltage being applied matches the voltage shown on the actuator's identification label and connect the power supply cables to the DIN plug(s) as per the wiring diagram affixed to the side of the actuator. Removing any label will invalidate the warranty. Wiring can be the same for AC or DC (3 wire), or 2 wire DC with a customer supplied voltage polarity switch, which is needed to reverse the motor. If in doubt, ASK BEFORE CONNECTING. Ensure that the rubber seal is refitted between the Din plug and base to maintain the IP65 seal. Do not over-tighten the plug securing screw.
- I.2 Do not connect a power supply voltage in excess of 48V to the low voltage (J2-L) series as irreparable damage will be caused and any warranty invalidated.
- I.3 If the volt free plug is not being used, leave the plug fitted to the actuator to maintain its IP65 weatherproof rating. Take care not to knock the DIN plugs as this may pull the DIN plug base away from the actuator which in turn will break the body seal and permit water to access the housing. Damage of this nature invalidates any warranty.
- I.4 All J2 actuators are supplied with volt free position confirmation switches (limit switches) that require a separate power supply to operate (rated 240V 5A) The suggested wiring as per the wiring diagram affixed to the side of the actuator shows the same voltage for the actuator being used as the power source for these switches – this is a suggestion only and any standard control voltage can be used (eg: 24VDC).
- I.5 Whilst the J2 actuators can be fitted in any orientation we recommend installing the actuator vertically wherever possible. Be aware of applications where elevated temperatures could be present and allow for the possibility of heat rising – in these cases use an extended mounting kit to help dissipate the heat, and mount the actuator horizontally.

OPERATING INSTRUCTIONS

These actuators work with the use of cams which operate limit switches which control the starting, stopping, and direction of rotation of an electric motor. These cams are factory set at 0 and 90 degrees and whilst they are adjustable, should not normally require any user adjustment.

- O.1 Supply a continuous (not pulse) live signal (either open live, or close live) to operate the actuator. The actuator will rotate until the cams operate the micro switch and cut the power to the motor. The actuator will stay in this position until a further continuous live signal is received to send it to its opposite position. The in-built heater uses this mains supply and therefore the power supply voltage should remain on at all times.
- O.2 The rest positions are as per the moulded open and closed logos, indicated by a local visual position indicator. NEVER move the set position of this indicator or a false position will be indicated.
- O.3 In the case of mains power failure, the actuator will stay in the position it saw at the moment of power interruption. Should the actuator need to be operated under these circumstances, use the manual override facility, but remember to reset the selector lever in the AUTO position when the movement is completed as selection of 'MAN' cuts the power to the motor.
- O.4 All J2 actuators have an electronic torque limiter which cuts the motor power if the applied torque exceeds the actuators rated output. Visual status indication is provided in models 20 & 55 by an internal LED which remains continuously lit when working normally, but flashes when the limiter is activated. A flashing LED indicates a problem with the valve, not the actuator. (Cut the power, clear the cause of the excess torque eg: valve jammed, turn power back on and the limiter will reset allowing normal operation)

MANUAL OVERRIDE

- 1.1 All J2 actuators have a manual override facility, operated by a selector lever which disengages the motor drive when moved from AUTO to MAN (Manual). The gearbox contains planetary gears and it may be necessary to 'wiggle' the selector lever whilst gently moving the manual override handle to ensure the gears disengage and re-engage. When resetting into AUTO – a positive 'click' will be felt when the gears have correctly re-engaged. A safety cut out switch activated by the manual override selector lever, which cuts the power to the motor when in the MAN position. When MAN is selected, the actuator will not operate electrically.
- 1.2 NEVER remove the selector lever retaining screw as this will allow the operating mechanism to become free and will cause irreparable damage to the actuator's gearbox. Removing this screw will invalidate any warranty.
- 1.3 When in AUTO mode, the manual override operating handle rotates on models 20 & 55 – restricting this rotation may activate the ETL. In these circumstances, switch off the power, leave a few seconds and turn back on – the ETL will automatically reset
- 1.4 When in MAN mode, avoid rotating the actuator beyond the open and closed logos moulded on the top of the actuator. There are no mechanical stops fitted to the actuator (to allow rotations of 120 and 180 degrees) and it is therefore possible to over rotate the actuator. Over rotation will position the internal cams beyond their micro switches which will result in abnormal first following operation of the actuator when reset into AUTO mode (the actuator may rotate up to 450 degrees until the cam resets in the correct position).

A yellow indicator identifies the open and closed logos:



MAINTENANCE

- M.1 These actuators are designed to be maintenance free, the gearbox is factory lubricated for life and there are no internal parts that require maintenance.

EXTRA INSTRUCTIONS
J+J REVERSIBLE ACTUATOR WITH POSITIONER

These instructions are to be read in conjunction with the Installation, Operation and Maintenance instructions for STANDARD POWER OPEN/ POWER CLOSE actuators.

• **WARNING**

Read these instructions BEFORE you start to handle the actuator as incorrect operation of the manual override can cause irreparable damage which will invalidate any warranty.

INSTALLATION:

As per standard power open/ power close actuators. If you proceed to use physical travel stops, ensure they are set to take effect BEYOND the travel limit of the actuator. If not, the actuator's torque limiter will operate when the stop is reached, and would need to be reset before correct operation can resume.

OPERATION

Irreparable damage can very easily be caused to the J+J actuators fitted with positioners due to incorrect operation. The positioners are factory set at 0 – 90 degrees and should not, under normal circumstances, require further adjustment. DO NOT attempt to adjust the positioner. If in any doubt, call your distributor.

- 1 Connect as per the wiring diagram affixed to the side of the actuator. If in any doubt, contact your supplier for wiring details BEFORE you attempt to wire the Din plugs. All connections are made via the external Din plugs and there is no need to remove the actuator cover to connect electrically. Removal of the cover may invalidate any warranty.
- 2 Connect the control signal input (and output, if required) cables to the control Din plug ensuring that the polarity of the control signal is as per the wiring diagram affixed to the side of the actuator.
- 3 If required, connect the volt free position confirmation cables as per the wiring diagram affixed to the side of the actuator. Note we have shown the supply to the position confirmation plug as the same as the power supply to the actuator – this is a suggestion only and any normal control voltage (eg: 24DC) can be applied to these volt free contacts.
- 4 Ensuring there is no physical restriction to the free rotation of the actuated assembly, apply power to the power Din plug, and a control signal to the control Din plug. Standard control signals are:
4-20mA positioners: 4mA closed 20mA open
0-10v positioners: 0 V closed 10 V open
If the output signal is being used, check that the output equals the input signal.
- 5 Changing the control signal will cause an equal percentage movement of the actuator, ie: 12mA = 45 degrees movement, or 5 V = 45 degrees movement.
A local visual position indicator will show the actuator's position locally.
If the actuator does not respond to control signal changes, check the polarity of the control signal wiring as incorrectly wired control signal plugs will cause incorrect operation of the positioner.
- 6 For emergency use, a manual override is supplied, operated by the used of the MAN/ AUTO selector lever fitted to the side of the actuator. Use of the manual override is as per the standard instructions, **however, take note of the following warning;**

WARNING – USE OF MANUAL OVERRIDE

An internally fitted gearwheel is fixed to the actuator's output shaft – this gear is the physical link from the positioner's circuitry to the actual output shaft position. This gear is connected to a potentiometer which has a MAXIMUM ROTATION OF 110 DEGREES. Rotation beyond this will irreparably damage the potentiometer and invalidate any warranty.

IT IS ABSOLUTELY CRITICAL THEREFORE, NOT TO ROTATE THE ACTUATOR BEYOND THE 0° TO 90° LOGOS MARKED ON THE TOP OF THE ACTUATOR (SEE STANDARD ACTUATOR INSTRUCTIONS WHICH SHOW HOW OPEN AND CLOSED ARE MARKED).

In all models there is a safety cut out switch operated by the manual override selector lever, which cuts power to the motor. If you have operated the actuator by use of the manual override and can not restart the actuator, check that the manual override selector lever has been reset in the AUTO position.

MAINTENANCE

As per the standard Installation, Operation and Maintenance instructions.

Many thanks for using the J+J reversible electric actuator with positioner. Correctly installed, connected and operated in accordance with these instructions should give you reliable and trouble free performance.

Rev2/104